

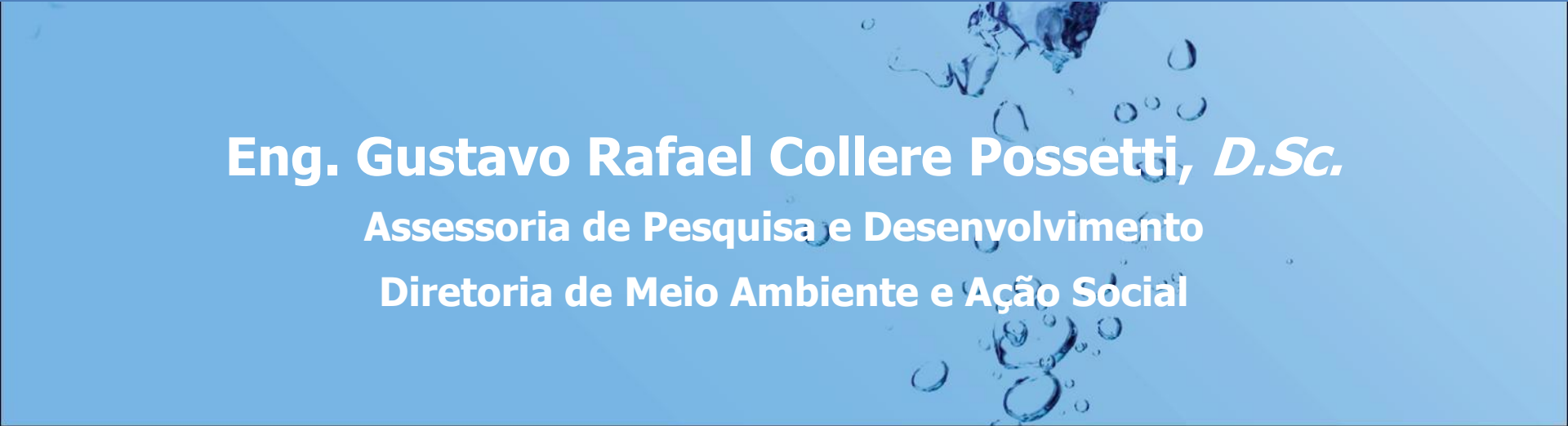

EXPERIÊNCIAS DA SANEPAR EM GESTÃO SUSTENTÁVEL DE ENERGIA



Eng. Gustavo Rafael Collere Possetti, *D.Sc.*
Assessoria de Pesquisa e Desenvolvimento
Diretoria de Meio Ambiente e Ação Social

MISSÃO

“Prestar **serviços de saneamento ambiental** de forma sustentável, contribuindo para a melhoria da qualidade de vida”

VISÃO

“Ser uma empresa de excelência, comprometida com a **universalização** do saneamento ambiental”

ÁGUA



~ 11 milhões hab.
164 ETAs
3.025.780 ligações
~ 51,6 mil km rede

ESGOTO



~ 7,1 milhões hab.
239 ETEs
1.953.484 ligações
~ 33,1 mil km rede

RESÍDUO SÓLIDO



~ 276 mil hab.
3 aterros sanitários
50,7 mil ton/ano

ENERGIA ELÉTRICA NA SANEPAR

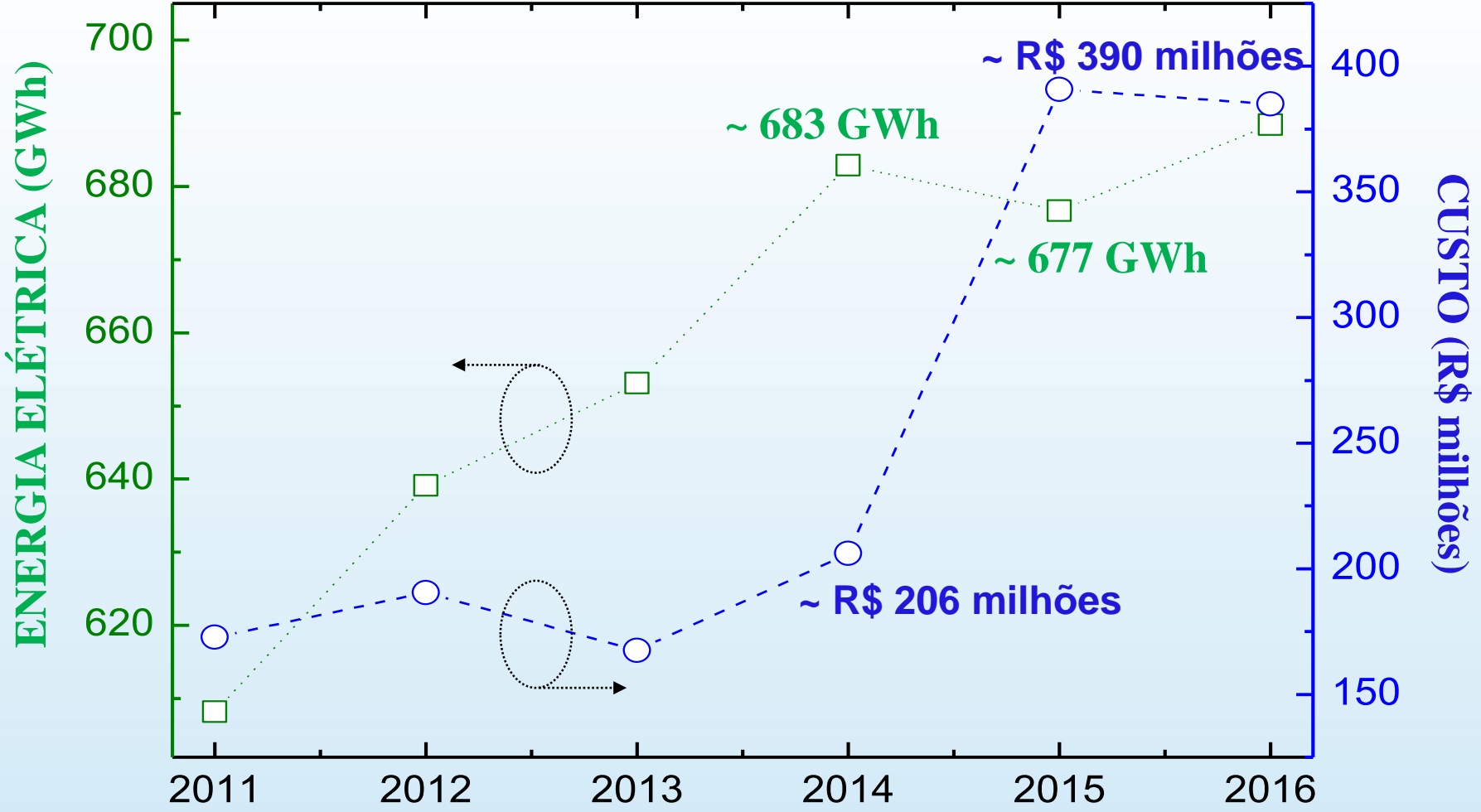

Fonte: SANEPAR (2017)

1. INSTITUCIONAL

2. GESTÃO DO CONSUMO

3. EFICIENTIZAÇÃO

4. ENERGIAS ALTERNATIVAS

5. COMUNICAÇÃO

**PLANO DE GESTÃO ENERGÉTICA
SUSTENTÁVEL DA SANEPAR**

GERENCIAMENTO DAS FATURAS DE ENERGIA ELÉTRICA



➤ **SGF:** Sistema de Gerenciamento das Faturas de Energia Elétrica

Gestão regionalizada de contas e contratos

Recálculo de valores faturados

Atualização de cadastro

Indicadores: kWh/m³ e R\$/kWh

Estudo de opção tarifária

Gestão dos adicionais

Excedente reativo
baixo fator de potência

Ultrapassagem de
demanda
medido > contratado

Adicional de demanda
medido < contratado

Economia (últimos 10 anos): ~R\$ 25 milhões

MONITORAMENTO EM TEMPO REAL DE UNIDADES



ETA IRAÍ



ETE PADILHA SUL

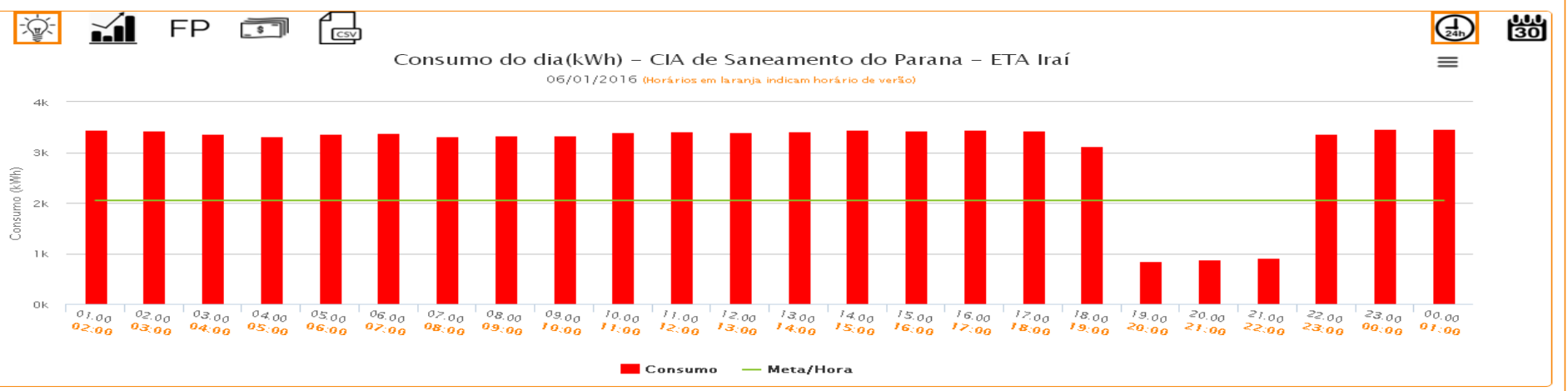

Exemplo de resultado com “parada” em horário de ponta:

Economia no SAIC-Curitiba: ~R\$ 1,8 milhões/ano

PERDAS DE ÁGUA NA SANEPAR



Índice de Perdas por Ligação (litros/lig./dia)

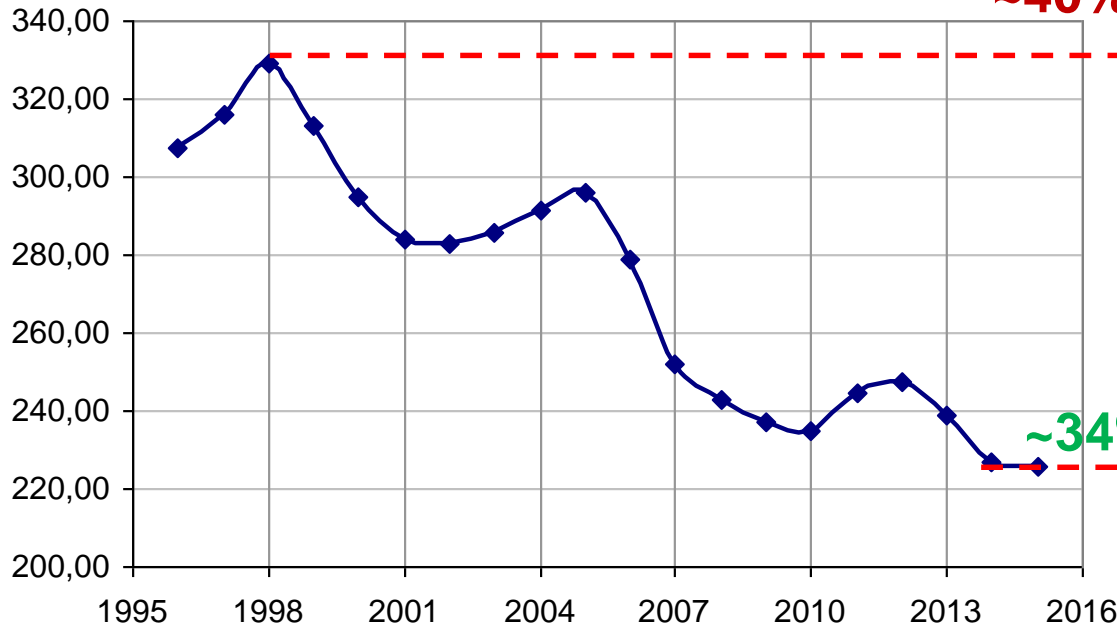

~40%

103,3 litros/ligação/dia

~112 milhões de m³
de água por ano

Economia média (energia e produto químico): ~R\$ 32 milhões por ano

Incremento médio de receita: ~R\$ 30 milhões por ano

INTERNET DAS COISAS



INTERNET OF THINGS
IoT



ELCOSUL

ORACLE®

Schneider Electric

| | | | |
|--|---------------------------------------|--|--|
| DATA: 25/03/17 HORA: 19:58:23 SITUAÇÃO: OK | 24 Nível R1 SITUAÇÃO: OK | DATA: 25/03/17 HORA: 19:58:23 SITUAÇÃO: OK | 122 Nível R2 SITUAÇÃO: OK |
| DATA: 25/03/17 HORA: 19:58:23 SITUAÇÃO: OK | 73 Pressão Jusante SITUAÇÃO: OK | DATA: 25/03/17 HORA: 19:58:23 SITUAÇÃO: OK | 49 Pressão Montante SITUAÇÃO: OK |
| DATA: 25/03/17 HORA: 19:58:23 SITUAÇÃO: OK | 98 Pressão Crítica SITUAÇÃO: OK | DATA: 25/03/17 HORA: 19:58:23 SITUAÇÃO: OK | 98 Vazão SITUAÇÃO: OK |



EFICIÊNCIA ENERGÉTICA EM SISTEMAS DE ABASTECIMENTO DE ÁGUA



Projeto de Eficiência Energética em
Sistemas de Abastecimento de Água



Ministério
das Cidades



ELÉTRICO



HIDRÁULICO



PROCESSO



EFICIÊNCIA ENERGÉTICA: USINA VIRTUAL DE ENERGIA

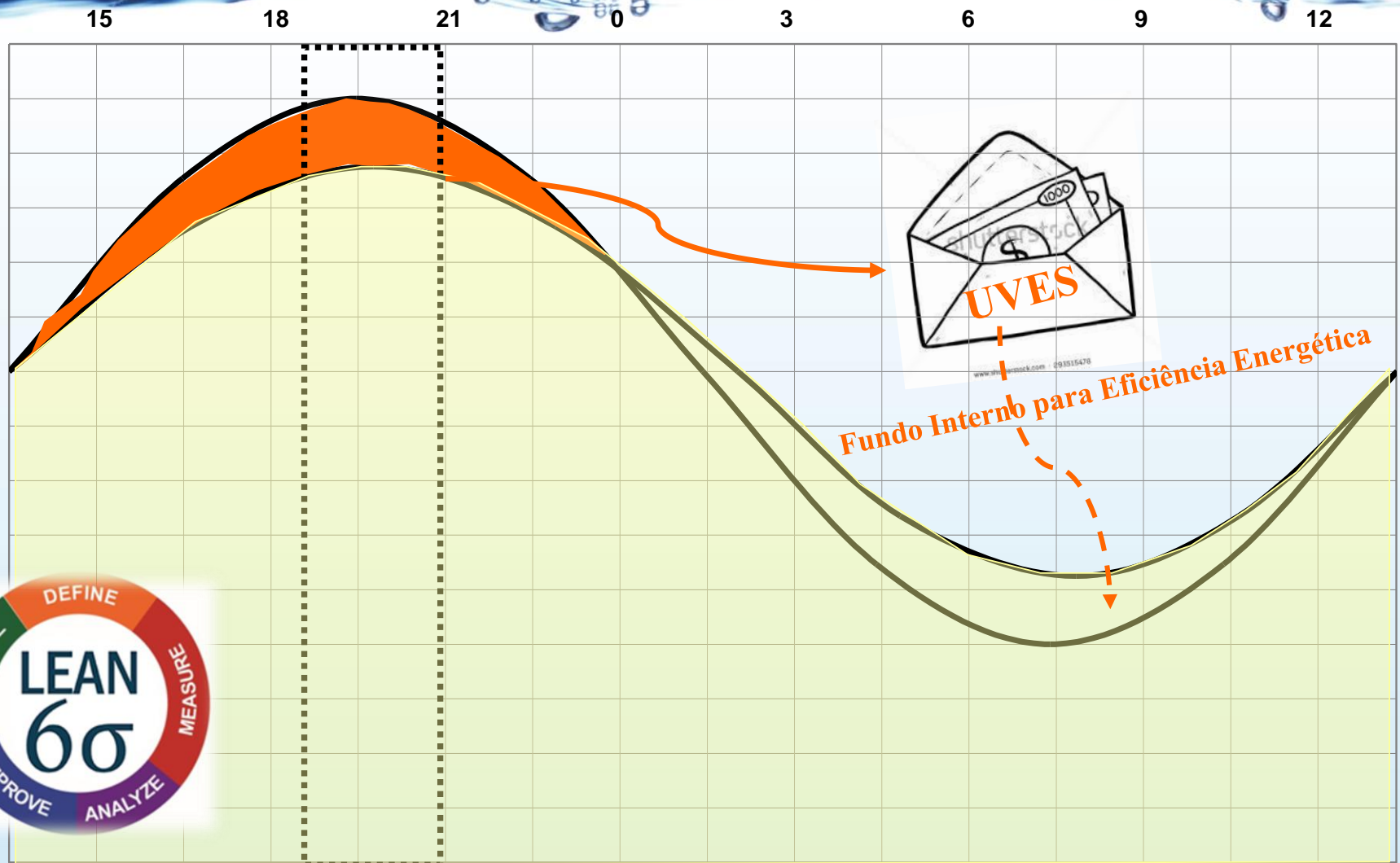

RELAÇÃO ENTRE PERDAS ELÉTRICAS, HIDRÁULICAS E REDUÇÃO DE CUSTOS

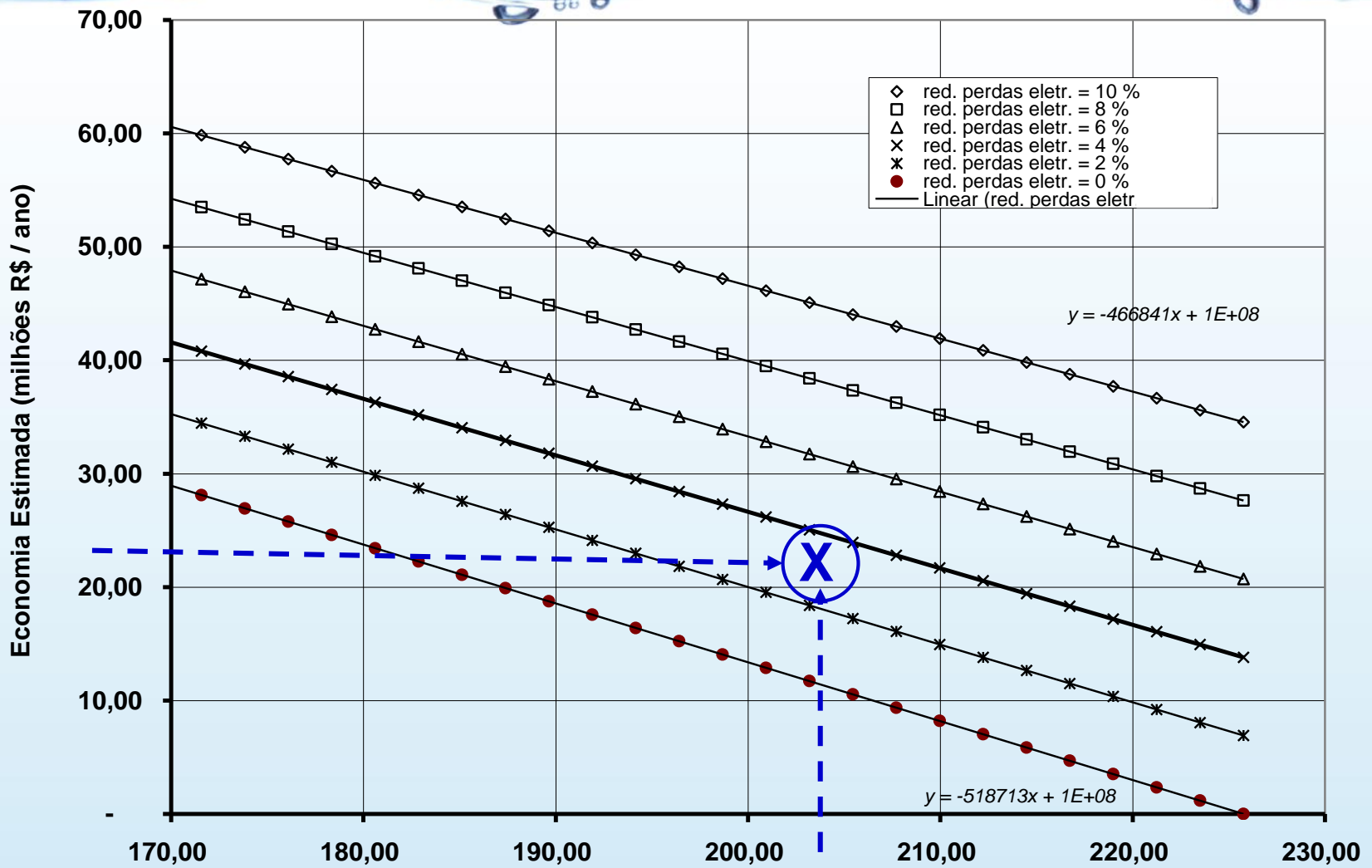

Fonte: dos Anjos Jr. (2017)

Indice de Perda p/ Ligação (L/lig.dia)

MICROGERAÇÃO HIDROENERGÉTICA EM REDES DE DISTRIBUIÇÃO



RESERVATÓRIO DE ÁGUA APOIADO SÃO JOSÉ AEROPORTO

- ⇒ Dados operacionais: $Q = 164 \text{ L/s}$
 $\Delta P = 24 \text{ mca}$
- ⇒ Potência: $\sim 18 \text{ kW}_e$ ($\sim 25\%$ do consumo da unidade)



QUANTIFICAÇÃO DE BIOGÁS EM ETEs



PROBIOGÁS

MEDIÇÕES (EM TEMPO REAL):

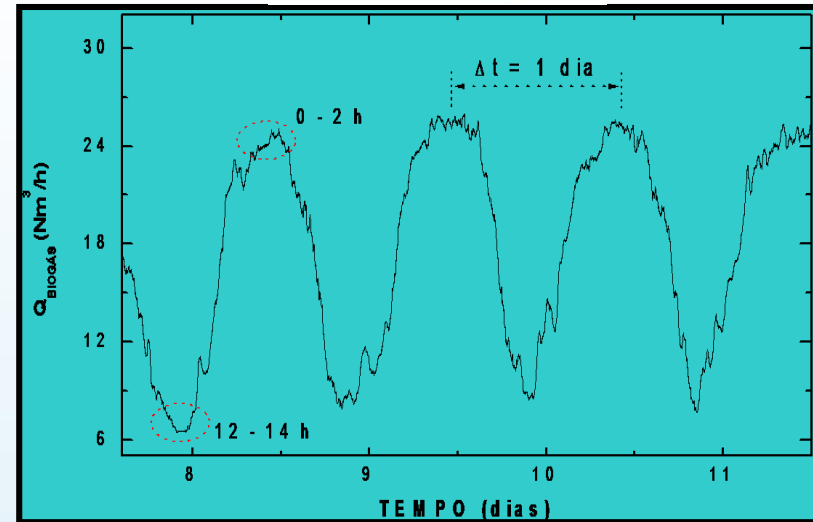
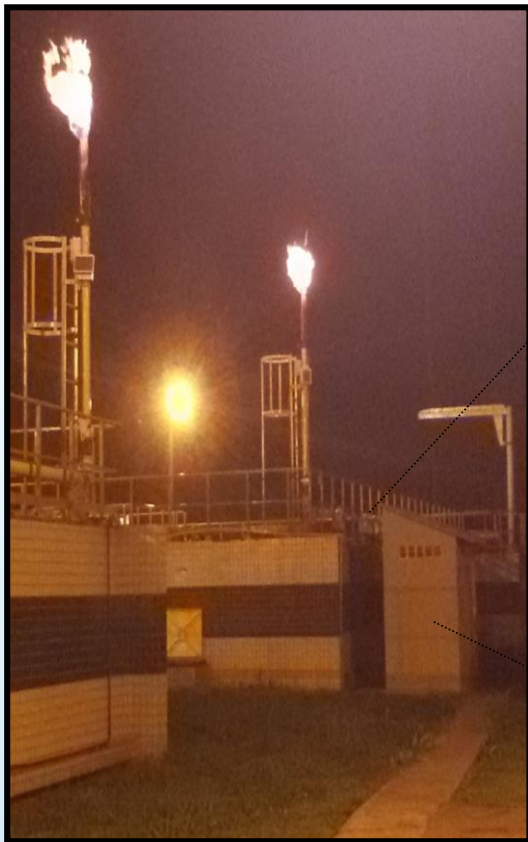

COMPORTAMENTO:

VARIÁVEL
PERIÓDICO
NÃO-ESTACIONÁRIO

“SISTEMA DE INFORMAÇÕES SOBRE POTENCIAL DE PRODUÇÃO DE BIOGÁS”

QUANTO DE BIOGÁS ESTÁ DISPONÍVEL?

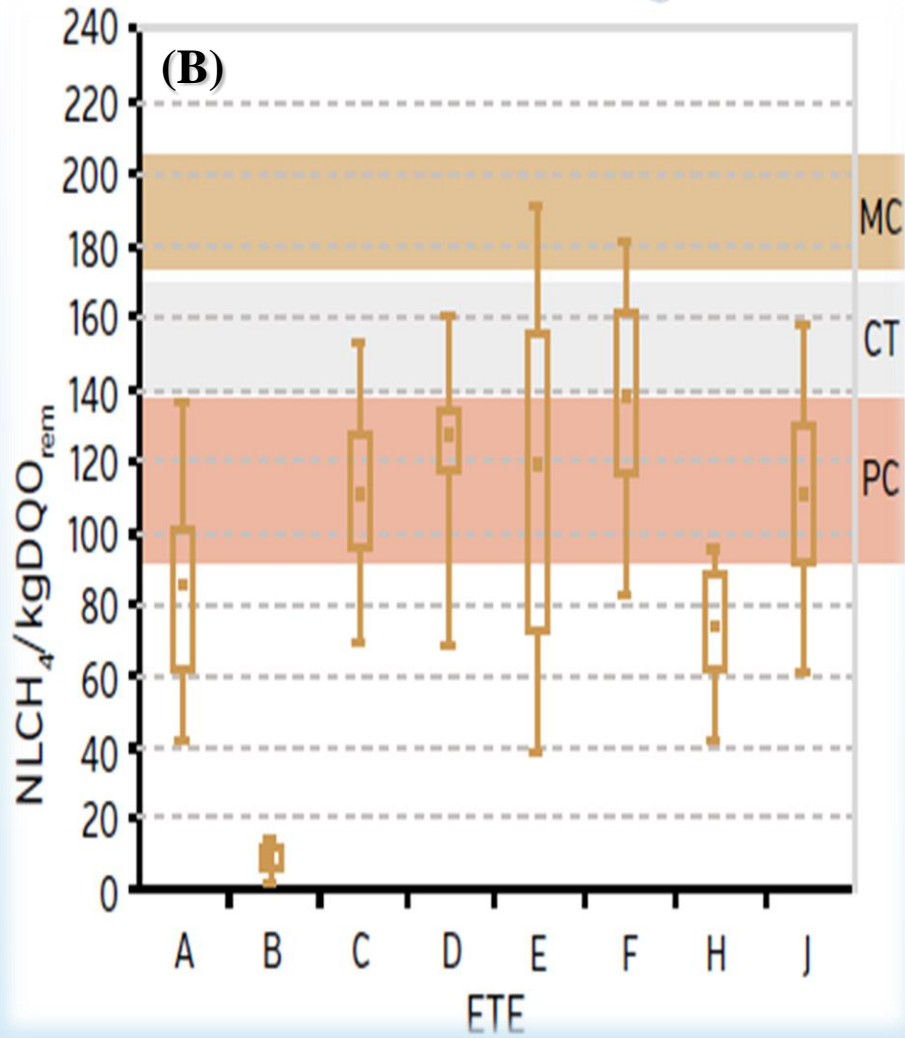
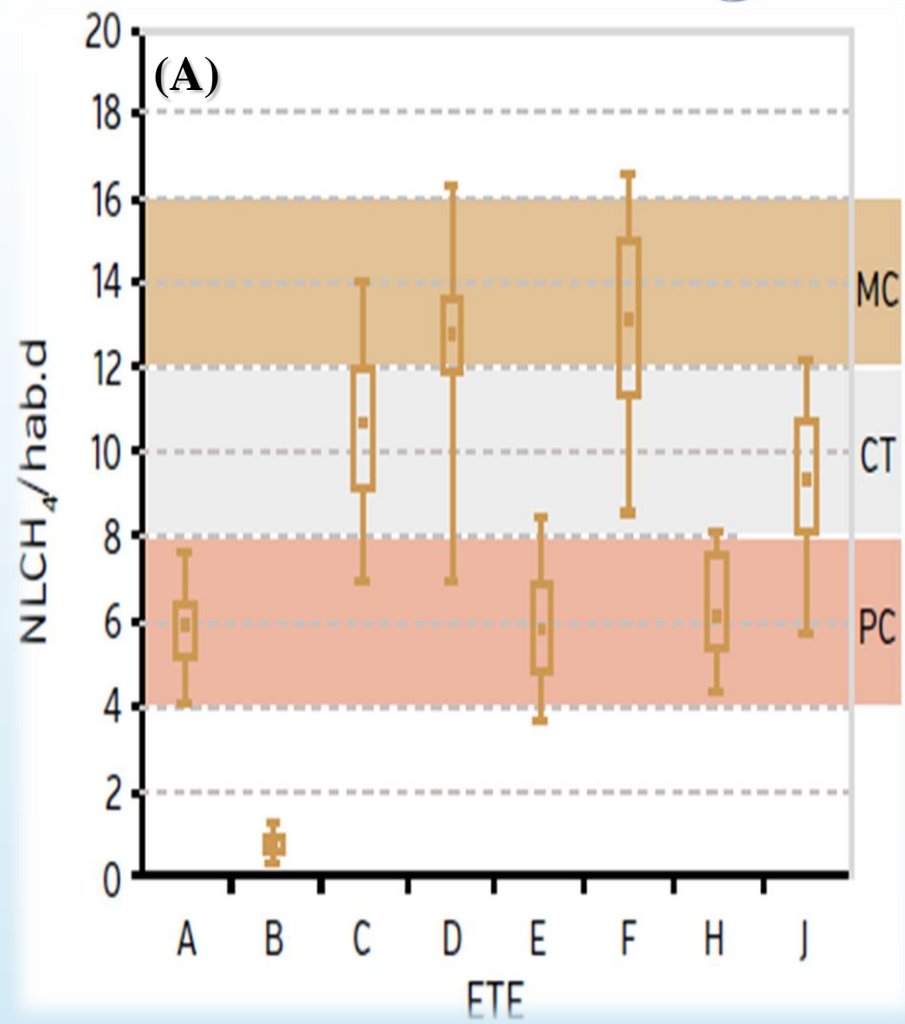

Fonte: PROBIOGÁS (2017)

QUAIS FATORES INFLUENCIAM A TAXA DE PRODUÇÃO DE BIOGÁS?

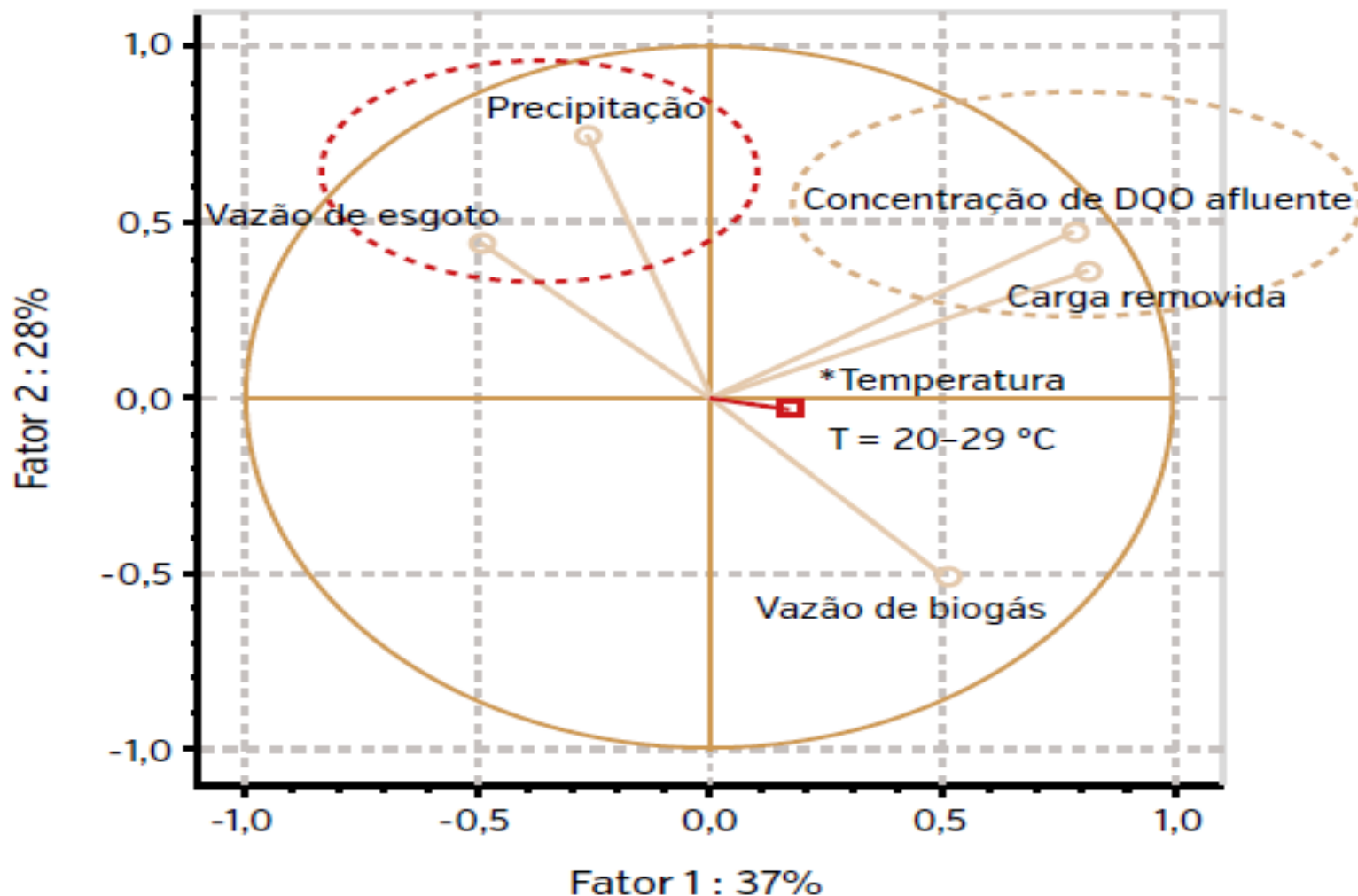

RECUPERAÇÃO DE BIOGÁS DISSOLVIDO NO ESGOTO



DiMeR GmbH

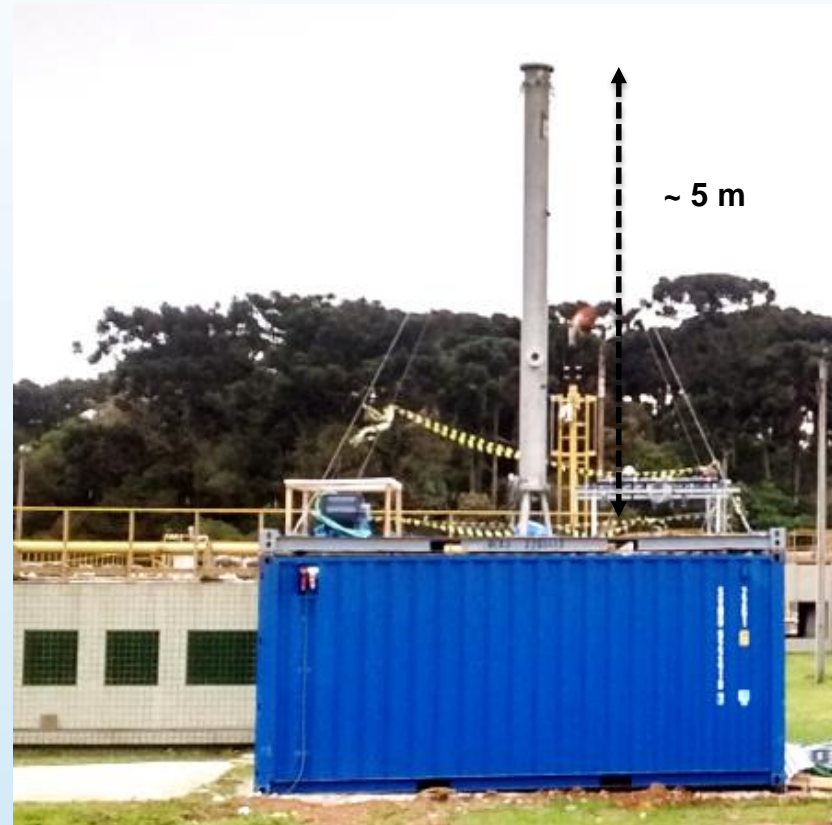
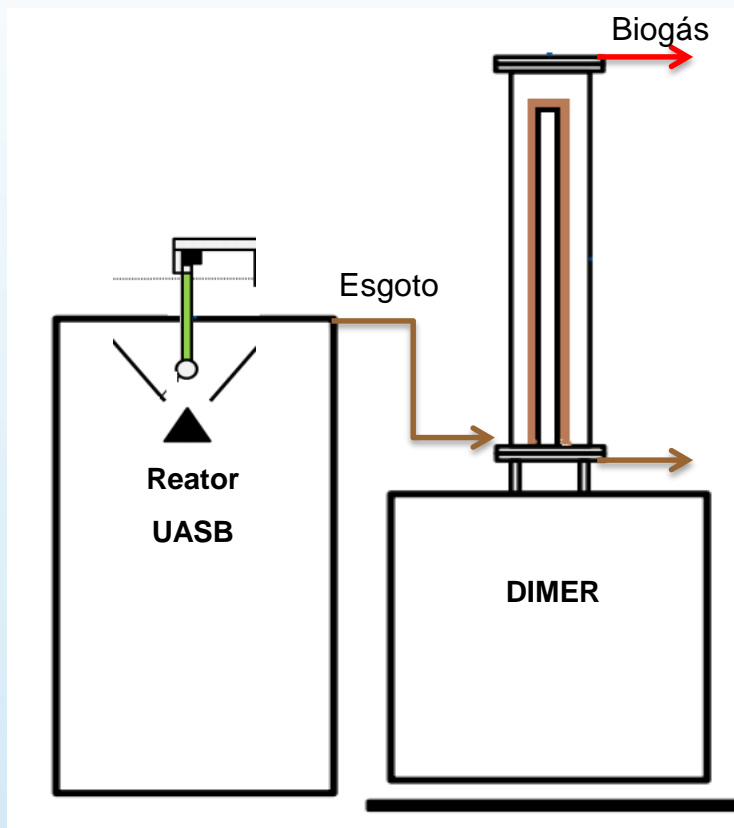

ESTIMATIVAS DE BIOGÁS EM ETEs

SOFTWARE:

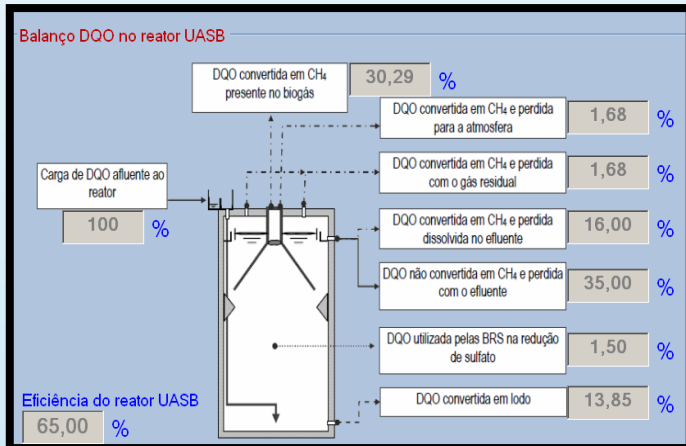
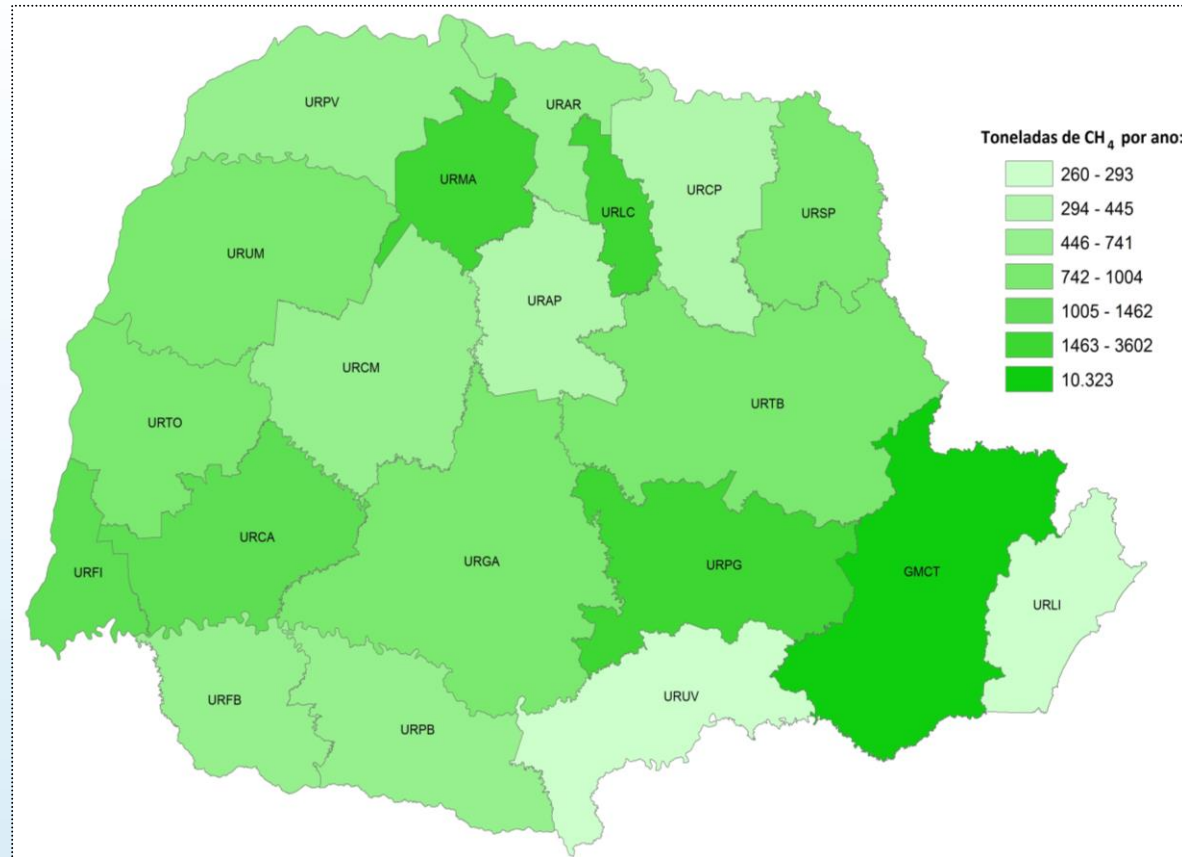

~ 31,4 x 10³ tonCH₄/ano

GERAÇÃO DISTRIBUÍDA DE ENERGIA ELÉTRICA A PARTIR DO BIOGÁS



ETE OURO VERDE – FOZ DO IGUAÇU (ONLINE):

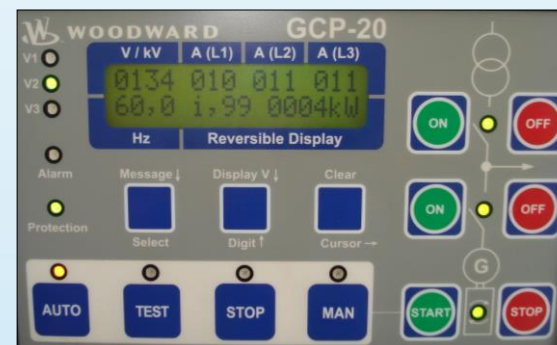
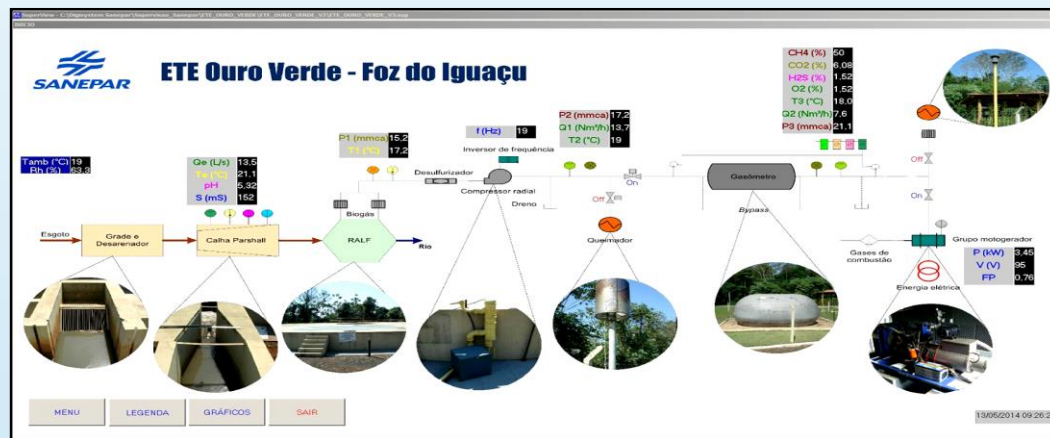
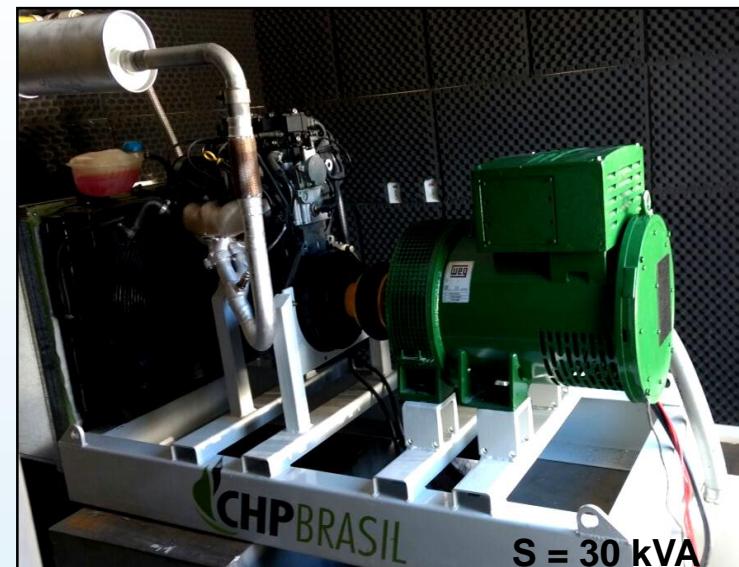

NET METERING

GERAÇÃO DE ENERGIA ELÉTRICA: ETE BELÉM – CS BIOENERGIA



- Lodo: 900 m³/dia
- RSU: 120 ton/dia
- Biogás: 20.000 m³/dia
- Eletricidade: 21 GWh/ano

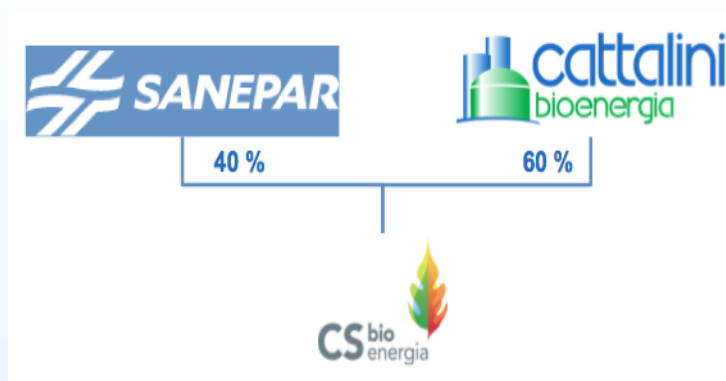

TRATAMENTO TÉRMICO E USO ENERGÉTICO DE LODOS E ESCUMAS



ALTERNATIVA PARA ETEs DE GRANDE PORTE:

① SECAGEM



② COMBUSTÃO



CINZAS

LODO EM
COMBUSTÃO

LODO SECO

- REDUÇÃO EM MASSA

- AUTOSSUSTENTABILIDADE ENERGÉTICA

BALANÇO DE MASSA: SISTEMA PILOTO DE SECAGEM E COMBUSTÃO DE LODOS



LODO ÚMIDO
(123 ± 37) kg/h

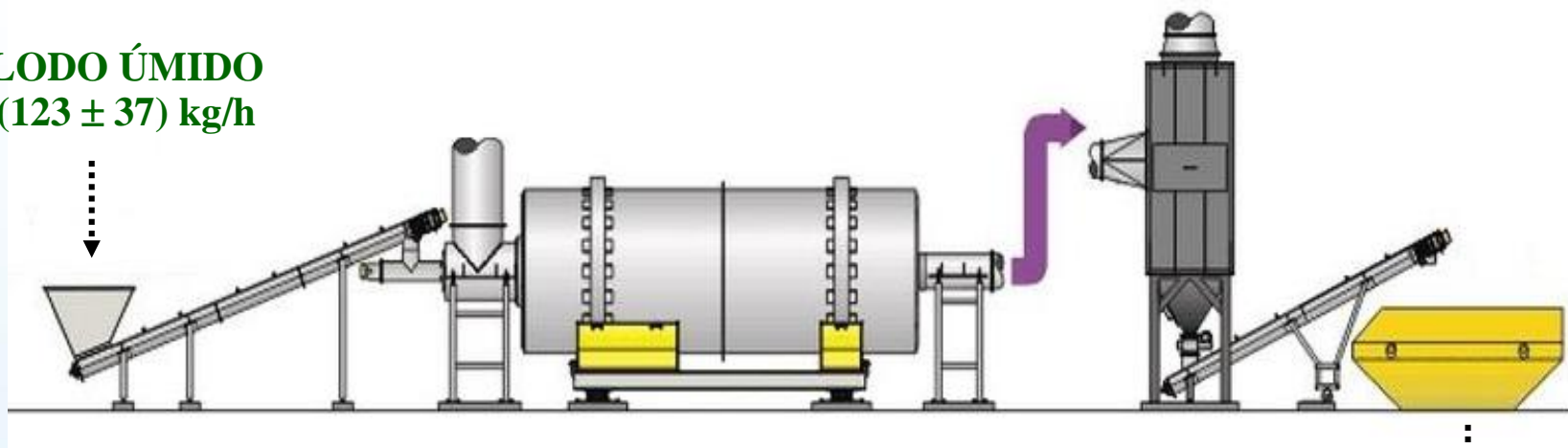

LODO SECO
(43 ± 7) kg/h

REDUÇÃO: ~90 %

CINZAS
(13 ± 3) kg/h

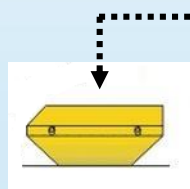

TRATAMENTO TÉRMICO DE LODOS

ENERGIA



SOLAR

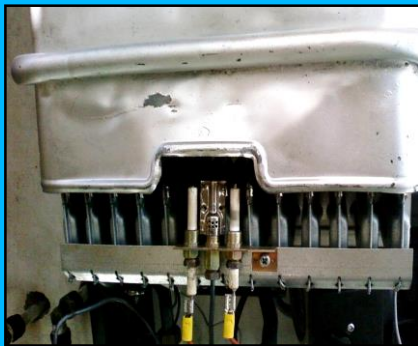

BIOGÁS

TRANSFERÊNCIA DE CALOR



PISO RADIANTE



LEITO DE HIGIENIZAÇÃO

ALTERNATIVA PARA ETES DE PEQUENO E MÉDIO PORTE

CONTINUAÇÃO ...



KFW

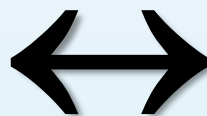

PROGRAMA PARANÁ BEM-TRATADO:

€ 50.000.000,00

ENERGIA SOLAR + EÓLICA: SISTEMA DE DESSALINIZAÇÃO



PRAIA DE LESTE: ~3 kWe



ENERGIA SOLAR: PRÓXIMAS ETAPAS



ETA MIRINGUAVA – CURITIBA



ETA TIBAGI – LONDRINA



RESERVATÓRIO PASSAÚNA - CURITIBA



PRÉDIO CORPORATIVO – LEED GOLD: 9,600 m²

~195 kWp



ENERGIA SOLAR: AVALIAÇÃO DE NOVOS MODELOS DE NEGÓCIO



AMSA WATERTREATMENT CENTER



SEONAM WASTEWATER TREATMENT CENTER



CAPACITAÇÕES E PRÊMIOS



**PRÊMIO
SANEPAR
DE TECNOLOGIAS
SUSTENTÁVEIS**
EFICIÊNCIA ENERGÉTICA NO SANEAMENTO



PRÊMIO SANEPAR DE TECNOLOGIAS SUSTENTÁVEIS

EFICIÊNCIA ENERGÉTICA NO SANEAMENTO

Trabalhos contemplados no Prêmio Sanepar de Tecnologias Sustentáveis e no Prêmio Inova Sanepar – Edição 2016



GESTÃO DE ENERGIA → SUSTENTABILIDADE

OPORTUNIDADES

X

DESAFIOS





OBRIGADO !

Eng. Gustavo Rafael Collere Possetti, *D.Sc.*

gustavorcp@sanepar.com.br

(41) 3777-7264

CETS - CENTRO DE TECNOLOGIAS SUSTENTÁVEIS SANEPAR

